

The other is that found for dimethyltin difluoride;¹¹ it is similar to that above, except that the tin and fluorine atoms form an infinite sheet with the formula $(\text{SnF}_2)_\infty$, the Sn-C bonds being perpendicular to the infinite sheet. The local symmetry of the metal atom is D_{2h} in the former but D_{4h} in the latter. The former structure is the more likely for the dimethyllead dihalides, because the latter involves linear or nearly linear metal-halogen-metal bonds, and these are rarely found other than for fluoro complexes.

On the basis of D_{2h} selection rules, the Pb-C stretching frequencies are of the following types: a_g (Raman active only) and b_{1u} (infrared active only). The spectra of the compounds are consistent with these predictions: the lower frequency band in each case (at 460 and 447 cm^{-1} for chloride and bromide, respectively) occurs as a very strong band in the Raman spectra only and is accordingly assigned as the symmetric Pb-C stretch; the higher frequency band in each case (at 534 and 523 cm^{-1} for chloride and bromide, respectively) occurs as a weak band in the infrared spectra only and is assigned as the asymmetric Pb-C stretch.

(c) **Pb-X Stretching Frequencies.** The halogen-bridged polymeric nature of the dimethyllead halides in the solid state is most clearly demonstrated by the low values for the Pb-X stretching frequencies. These occur in the range 159–202 cm^{-1} for the chloride, when values of about 300 cm^{-1} would be expected for the monomeric species, by analogy with the spectra of trimethyllead chloride and dimethyltin dichloride in solution.^{6,8,9}

On the basis of D_{2h} selection rules, the PbX stretching frequencies are of the following types: a_g and b_{1g}

(Raman active only) and b_{2u} and b_{3u} (infrared active only). These selection rules are seen (Table IV) in general to hold well in the spectra of the compounds and provide some support for the suggested structure for the molecules. However, the bands are very broad, especially in the infrared, presumably as a result of solid-state splittings.

(d) **Skeletal Bending Frequencies.** The C-Pb-C bending frequencies occur near 100 cm^{-1} , but are not sufficiently detailed to warrant separate discussion.

Conclusion

Molecular weight measurements on the trimethyllead halides in benzene solution have shown that these compounds are monomers; vibrational spectral work is fully consistent with this conclusion. In the solid state, however, the spectral work in general, and especially that in the Pb-X stretching region, suggests that the compounds have halogen-bridged polymeric structures. The high melting points and low solubilities of the compounds also point to their polymeric nature. The lead atoms are probably five-coordinate with nearly planar PbC_3 groupings.

The dimethyllead dihalides were insufficiently soluble for solution studies, but in the solid state they are clearly polymeric on the bases of high melting points, low solubilities, and low Pb-X stretching frequencies. They are likely to be chain polymers with the diphenyllead dichloride structure.

The lead compounds have a greater tendency to polymerize than have the analogous tin compounds; this is consistent with the larger lead atoms greater preference for a higher coordination number.

The Kinetics and Mechanism of Nucleophilic Substitution in Nickel Tetracarbonyl

J. Philip Day, Fred Basolo, and Ralph G. Pearson

Contribution from the Department of Chemistry, Northwestern University, Evanston, Illinois 60201. Received July 11, 1968

Abstract: The rate of the substitution reaction (1) of nickel carbonyl with triphenylphosphine or carbon monoxide has been measured over a 30° temperature range, in solution in *n*-hexane and toluene (Ph_3P only), and in the gas phase (CO only). The reactions were followed by infrared spectrophotometry in the C-O stretching region, using C^{18}O for the CO exchange reactions. The rates are independent of concentration or type of nucleophile, but first order with respect to $\text{Ni}(\text{CO})_4$ concentration. Rates of reaction in the gas phase or in toluene are *ca.* twice those in *n*-hexane, but activation parameters for all reactions are similar (ΔH^* from 22 to 24 kcal mol^{-1} , ΔS^* from +7 to +14 eu). In particular, and contrary to earlier results, CO and Ph_3P in the same solvent react with indistinguishable rates and activation parameters and compete for the same activated complex. Taken in conjunction with the results for the thermal decomposition of $\text{Ni}(\text{CO})_4$, in the following paper, the dissociative (SN1) mechanism (eq 9 and 10) is suggested for the reaction.

The object of the experiments reported here is to establish a plausible mechanism for the substitution reactions of nickel carbonyl (1), where $\text{L} = \text{CO}$, R_3P ,

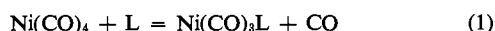

$(\text{RO})_3\text{P}$, RNC, and nucleophiles of similar type.

The position^{1,2} until recently was that CO reacted

by a mechanism different from other nucleophiles, the latter reacting by a common mechanism. Kinetic studies of ^{14}CO exchange (by radioactivity counting³⁻⁵)

(1) F. Basolo and R. G. Pearson, "Mechanisms of Inorganic Reactions," 2nd ed, John Wiley and Sons, Inc., New York, N. Y., 1967, p 543.

(2) D. A. Brown, *Inorg. Chim. Acta Rev.*, **1**, 39 (1967).

(3) F. Basolo and A. Wojcicki, *J. Am. Chem. Soc.*, **83**, 520 (1961).

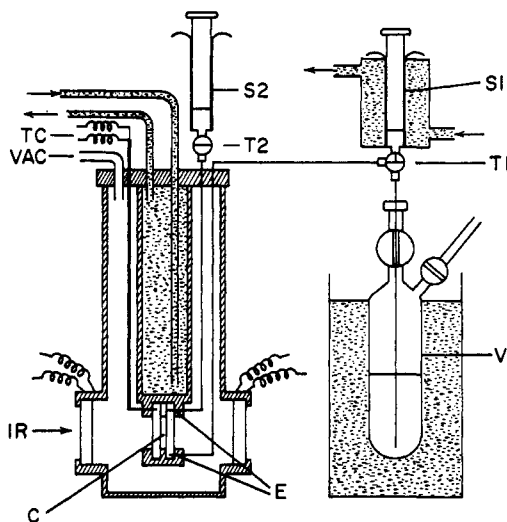

Figure 1. Variable low-temperature infrared cell and inlet system. V, storage vessel at -40° ; S1 and S2, 10-ml syringes; T1 and T2, stopcocks; C, infrared cell; E, entry ports for cell; TC, thermocouple connections; VAC, vacuum connection; IR, position of infrared beam.

and of ligand substitution (by CO evolution⁴⁻⁶ or infrared spectrophotometry⁷) in several solvents had shown that a first-order rate law was obeyed (rate = $k[\text{Ni}(\text{CO})_4]$). At 25° , all nucleophiles reacted at approximately equal rates. However, the activation parameters for CO exchange (ΔH^* from 10 to 12 kcal mol⁻¹, ΔS^* from -26 to -36 eu, dependent on solvent) indicated a difference from substitutions by other ligands, for which the activation parameters were essentially independent of ligand type (ΔH^* from 21 to 26 kcal mol⁻¹, $\Delta S^* \approx 2$ eu, dependent on solvent). It was suggested⁴ that the simple dissociative mechanism originally postulated for CO exchange³ could not apply to both types of reactions, and various mechanistic alternatives have been considered.¹

In a recent communication,⁸ we reported new measurements of the rates of CO exchange and Ph_3P substitution. The reactions were followed by infrared spectrophotometry in the C-O stretching region, using C^{18}O for the exchange. The results did not confirm those obtained previously for CO exchange and suggested that both nucleophiles reacted by the same mechanism. We now substantiate these findings and extend the study to CO exchange in the gas phase. This is to provide a link with the new study of the thermal decomposition of $\text{Ni}(\text{CO})_4$, which we report in the following paper.⁹ The results, taken together, suggest a single dissociative mechanism (SN1 type) for reaction 1.

Experimental Section

General. Nickel carbonyl is extremely poisonous. The maximum allowable concentration¹⁰ for extensive inhalation has been

(4) L. R. Kangas, R. F. Heck, P. M. Henry, S. Breitschaft, E. M. Thorsteinson, and F. Basolo, *J. Am. Chem. Soc.*, **88**, 2334 (1966).

(5) P. M. Henry and L. R. Kangas, Abstracts, 154th National Meeting of the American Chemical Society, Chicago, Ill., Sept 1967, No. O11.

(6) R. F. Heck, *J. Am. Chem. Soc.*, **85**, 657 (1963).

(7) R. J. Angelici and B. E. Leech, *J. Organometal. Chem.*, **11**, 293 (1968).

(8) J. P. Day, F. Basolo, and R. G. Pearson, *J. Am. Chem. Soc.*, **90**, 1925 (1968).

(9) J. P. Day, R. G. Pearson, and F. Basolo, *ibid.*, **90**, 6933 (1968).

set at 1 part in 10^9 . It is the more dangerous because of its high volatility (bp 43°). In our experiments it was handled entirely within an enclosed system. Waste vapors were condensed in traps at -196° , and all nickel carbonyl waste was destroyed by treatment with solutions of bromine in carbon tetrachloride.

The nickel carbonyl was obtained from the Matheson Co. (Joliet, Ill.) and distilled three times, under carbon monoxide (ca. 1 cm pressure), from one trap at 0° to one at -196° . It was finally stored at ca. 1 atm total pressure as a 20% gas mixture with carbon monoxide. Solutions in *n*-hexane and toluene (both spectrograde, from Eastman Organic Chemicals, further dried by distillation from potassium under a nitrogen atmosphere) were prepared by distilling the nickel carbonyl into 50-ml flasks at -196° , removing the carbon monoxide and replacing it with nitrogen by repeated flushing, and adding a suitable volume of solvent. These stock solutions were stored at ca. -80° , in the dark, and were stable for several months. The concentrations were determined by analysis for nickel content (see below). Nickel carbonyl solutions were handled using gas-tight syringes, Teflon stopcocks, and syringe needles (Hamilton Co., Whittier, Calif.). Because of the possibility of the photodecomposition¹¹ of nickel carbonyl, the laboratory was illuminated by a photographic safelight only during all experiments with nickel carbonyl.

Triphenylphosphine (Aldrich Chemical Co., Milwaukee, Wis.) was purified by recrystallization from ethanol, under nitrogen, with subsequent removal of the occluded solvent by heating the triphenylphosphine at its melting point (82°) for 3 hr under vacuum. Solutions were prepared gravimetrically, under a nitrogen atmosphere. C^{18}O (ca. 90% ^{18}O) was obtained from Miles Laboratories, Inc., Elkhart, Ind. Concentrations of CO in solution were calculated from the pressure.¹²

Infrared measurements were carried out with a Perkin-Elmer 337 spectrophotometer coupled to an external potentiometric recorder. For gas reactions, a 5-cm glass cell with a water jacket and double sodium chloride windows was used. The space between the end windows (1 cm) was evacuated, and warm dry nitrogen was blown continuously onto the outer window when the cell was used below room temperature. This prevented water condensation. For reactions in solution a variable low-temperature cell unit (VLT-2 from Research and Industrial Instruments Co., London, available in the United States from Beckman Instruments, Inc., Fullerton, Calif.) was used; this incorporates a 1-mm sodium chloride cell.

Solution Reactions. Kinetic measurements were carried out between -20 and $+40^{\circ}$ as follows (see Figure 1). A solution containing known concentrations of $\text{Ni}(\text{C}^{18}\text{O})_4$ and nucleophile (C^{18}O and/or Ph_3P) was stored at ca. -40° (reaction rate negligible) in the vessel V. At "experimental zero time" a sample was withdrawn into the 10-ml syringe S1 (at the same temperature as the infrared cell) and then injected rapidly into the infrared cell C. Excess solution was collected in syringe S2. Then by closing stopcocks T1 and T2 the solution was isolated, essentially with no gas phase. The entry ports (E) of the cell are so narrow that it seemed reasonable to assume that diffusion between the cell and the inlet tubing during kinetic runs could be ignored. The cell temperature was controlled within 0.1° by pumping coolant (ethylene glycol-water) through the cell unit from a constant-temperature bath and was measured with a thermocouple (iron-constantan) inserted into one of the sodium chloride windows. To reduce the heating of the cell by the infrared beam, a shutter was used to cut this off whenever possible.

Gas-Phase Reactions. The components for the gas-phase reactions were assembled in a 50-ml flask attached to a vacuum line. The 20% $\text{Ni}(\text{CO})_4$ -CO gas mixture was admitted to a measured pressure, and the $\text{Ni}(\text{CO})_4$ frozen out at -196° . The CO was removed by repeated flushing with nitrogen. Finally, a measured volume of C^{18}O was added from a gas buret and the flask warmed to -20° . The $\text{Ni}(\text{CO})_4$ was then in the gas phase, and the total pressure was brought to ca. 1 atm with nitrogen. The gas mixture was then admitted into the (previously evacuated) infrared cell, at the reaction temperature (0 to $+30^{\circ}$).

Calibration and Analysis. The proportionality of $\text{Ni}(\text{CO})_4$ absorbance to concentration (Beer's law) was tested as follows. For

(10) "Threshold Limit Values for 1964," American Conference of Government-Industrial Scientists, quoted by H. E. Carlton and J. H. Oxley, *A.I.Ch.E. J.*, **13**, 86 (1967).

(11) A. P. Garratt and H. W. Thompson, *J. Chem. Soc.*, 1817 (1934).

(12) H. Stephen and T. Stephen, Ed., "Solubilities of Inorganic and Organic Compounds," Vol. I, The Macmillan Co., New York, N. Y., 1963, p 1053.

Table I. Rate Constants^a and Activation Parameters^b for the Reaction of Ni(C¹⁸O)₄ with C¹⁸O and Ph₃P, in Solution and in the Gas Phase

Temp, °C	Ph ₃ P substitution		Rate constant, ° 10 ⁴ k, sec ⁻¹		Gas phase
	Toluene	<i>n</i> -Hexane	<i>n</i> -Hexane	C ¹⁸ O exchange	
-20.0	0.215
0.0	5.58
0.5	...	2.45	2.50
10.0	...	11.0	12.5	...	23.8
10.1	29.2
20.0	93.2	49.8	52.0	...	94.7
30.0	...	206	210	...	348
31.2	434
39.9	1340
25.0 ^d	203	102	107	...	183
Δ <i>H</i> [*] , kcal mol ⁻¹	22.3 ± 0.2	24.2 ± 0.2	24.0 ± 0.4	...	22.1 ± 0.4
Δ <i>S</i> [*] , eu	8.4 ± 1	13.5 ± 1	13.1 ± 2	...	7.7 ± 2

^a Defined by eq 6 and 4. ^b Probable errors estimated from deviation and anticipated experimental errors. ^c Mean of three or more determinations at each temperature. Probable error: Ph₃P substitution, 1%; CO exchange, 2%. ^d Rate constants at 25° calculated from Arrhenius plot, for comparison with previous results.

the gas-phase case, the infrared cell and some 50-ml flasks fitted with stopcocks were filled to measured pressures with a stable Ni(CO)₄-CO gas mixture. The maximum absorbance (2058 cm⁻¹) was measured, and the flasks were analyzed for nickel content (see below), from which the Ni(CO)₄ concentration in the gas mixture was calculated. Beer's law was confirmed, and the effective molar extinction coefficient was 3.86 × 10³ l. mol⁻¹ cm⁻¹, with a standard deviation of 0.5% for ten measurements over the concentration range 10⁻³-10⁻⁶ M (gas phase at 28°).

The gas samples were analyzed for nickel as follows. The 50-ml flasks containing Ni(CO)₄ were cooled in liquid nitrogen, 2 ml of a solution of bromine in carbon tetrachloride was added, and the sealed flask was allowed to warm to room temperature. The resulting nickel(II) bromide was extracted into water and analyzed colorimetrically for nickel by the dimethylglyoxime method (Sandell¹³), using a Beckman DU-2 spectrophotometer. Calibration solutions were prepared from nickel ammonium sulfate.

To measure the extinction coefficient of Ni(CO)₄ in solution, a stock solution in *n*-hexane, ca. 10⁻² M, was first prepared and analyzed for nickel content as above. Then the maximum absorbance (2046 cm⁻¹) was measured for solutions from 10⁻² to 10⁻⁵ M, in 1.0- or 0.1-mm cells (the exact pathlength was determined by the interference-fringe method¹⁴). The effective molar extinction was 6.58 × 10³ l. mol⁻¹ cm⁻¹, with a standard deviation of 0.3% over ten measurements (*n*-hexane solution at 28°). It was observed that the extinction coefficients in both phases were somewhat dependent on the resolution setting of the spectrophotometer. The "effective" extinction coefficients quoted refer to measurements made at the "normal" setting of the instrument (nominal resolution ≈ 2 cm⁻¹) and could vary ± 5% under different conditions.

The wavelength calibration of the nickel carbonyl spectra was made against the spectrum¹⁵ of gaseous DCl.

Calculations. Where necessary, calculations were carried out on the Northwestern University CDC 6400 computer. Library program NUC-0062 was used for the numerical integration of differential equations by the Runge-Kutta method. Other programs were written specifically for each problem and used standard least-squares techniques.¹⁶

Results

Triphenylphosphine Substitutions. The rate of substitution was measured over a range of temperature in two solvents, toluene and *n*-hexane. The reaction was

(13) E. B. Sandell, "Colorimetric Methods of Analysis for Metals," Vol. 3, 3rd ed, Interscience Publishers, New York, N. Y., 1959, p 668.

(14) N. B. Colthup, L. H. Daly, and S. E. Wiberly, "Introduction to Infrared and Raman Spectroscopy," Academic Press, New York, N. Y., 1964, p 62.

(15) "Tables of Wavenumbers for the Calibration of Infrared Spectrometers," Report by the IUPAC Commission on Molecular Structure and Spectroscopy, Butterworth & Co. (Publishers) Ltd., London, 1961, p 583.

(16) H. D. Young, "Statistical Treatment of Experimental Data," McGraw-Hill Book Co., Inc., New York, N. Y., 1962, p 115.

characterized by the decay of the Ni(CO)₄ absorbance band (a 2046 cm⁻¹, in hexane) and the immediate appearance of two bands (b 2003, c 2071 cm⁻¹), followed by two further bands (d ~2005, e 1950 cm⁻¹). Band a finally disappeared and b and c reached a maximum intensity and later decayed. Bands b and c have previously been reported^{17,18} for the species Ni(CO)₃-Ph₃P, and d and e for Ni(CO)₂(Ph₃P)₂; their observed behavior is consistent with a stepwise substitution, *i.e.*



Provided that Ph₃P was present in slight excess, there was no sign that the reversal of (2) was important; the absorbance of Ni(CO)₄ followed a first-order decay for more than 95% of the reaction and effectively reached zero. The rate constants for (2), defined by (4), were obtained from plots of ln [Ni(CO)₄] against time and are given in Table I.

$$-\frac{d[\text{Ni(CO)}_4]}{dt} = k_{\text{sub}}[\text{Ni(CO)}_4] \quad (4)$$

The rate constants for reaction in toluene are about twice those for reaction in hexane, with slightly different activation parameters. At 20°, in either solvent, the rate constants showed an increase of ca. 10% over a 100-fold range (0.005-0.5 M) of Ph₃P starting concentration, at a constant starting concentration of Ni(CO)₄ of 0.001 M. The activation parameters are calculated from rate constants determined at the lowest Ph₃P concentration.

CO Exchange. The reaction of C¹⁸O with Ni(C¹⁶O)₄, in the gas phase and in solution, was followed by measuring infrared spectra in the C-O stretching region. The spectrum at various stages of the reaction in hexane is shown in Figure 2. The order of appearance of the bands allows an assignment to the appropriate Ni-(C¹⁸O)_{*n*}(C¹⁶O)_{4-*n*} species. The number of independent C-O vibrations and their activity in infrared absorbance is readily predicted for each species.¹⁹ However, the

(17) L. S. Meriwether and M. L. Fiene, *J. Am. Chem. Soc.*, **81**, 4200 (1959).

(18) M. Bigorgne, *Bull. Soc. Chim. France*, **27**, 1986 (1960).

(19) F. A. Cotton, "Chemical Applications of Group Theory," Interscience Publishers, New York, N. Y., 1963, p 245.

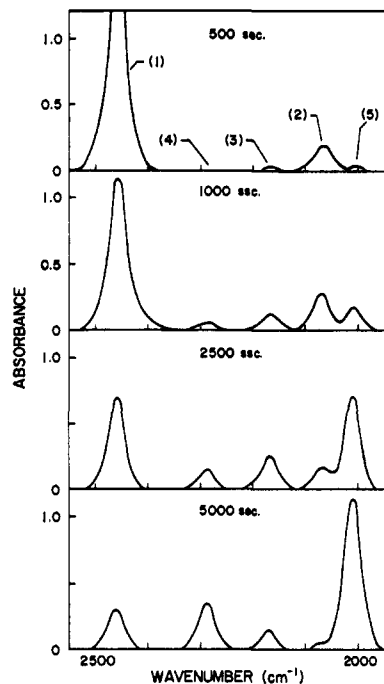

Figure 2. Infrared spectra at intervals during the reaction of $\text{Ni}(\text{C}^{16}\text{O})_4$ with C^{18}O in *n*-hexane at 10° : (1) $\text{Ni}(\text{C}^{16}\text{O})_4$, with contributions from other species; (2) $\text{Ni}(\text{C}^{18}\text{O})_3(\text{C}^{16}\text{O})$, the band used for kinetic measurements; (3) $\text{Ni}(\text{C}^{16}\text{O})_2(\text{C}^{18}\text{O})_2$; (4) $\text{Ni}(\text{C}^{16}\text{O})(\text{C}^{18}\text{O})_3$; (5) $\text{Ni}(\text{C}^{18}\text{O})_4$, with contributions from other species.

number of bands observed is less than this. Bor²⁰ and Haas and Sheline²¹ have compared the observed with the calculated spectra of the $\text{Ni}(\text{C}^{12}\text{CO})_n(\text{C}^{13}\text{CO})_{4-n}$ species and shown that some of the bands for the intermediate species ($n = 1, 2, 3$) are at the same wavelength as the terminal cases ($n = 0, 4$). We have made a parallel assignment (Table II) for the C^{18}O species,

Table II. Infrared Spectra in the C–O Stretching Region for $\text{Ni}(\text{C}^{16}\text{O})_n(\text{C}^{18}\text{O})_{4-n}$

Molecular species	Mode	Band position, ^a cm^{-1}	
		<i>n</i> -Hexane	Gas phase ^b
$\text{Ni}(\text{C}^{16}\text{O})_4$	A_1	Inactive	Inactive
	T_2	2046.0	2057.6
$\text{Ni}(\text{C}^{16}\text{O})_3(\text{C}^{18}\text{O})$	A_1	2116	
	A_1	2006.8	2018.4
$\text{Ni}(\text{C}^{16}\text{O})_2(\text{C}^{18}\text{O})_2$	E	(2046)	(2058)
	A_1	2107	
	A_1	2015.7	2027.2
	B_1	(2046)	(2058)
$\text{Ni}(\text{C}^{16}\text{O})(\text{C}^{18}\text{O})_3$	B_2	(1999)	(2010)
	A_1	2095	
	A_1	2027.3	2038.2
$\text{Ni}(\text{C}^{18}\text{O})_4$	E	(1999)	(2010)
	A_1	Inactive	Inactive
	T_2	1998.8	2010.4

^a Calibrated against spectrum of gaseous DCl. Estimated error 0.3 cm^{-1} . ^b Bands for gas-phase spectra broadened by rotational (PQR) structure.

noting only a small difference in band positions from the ^{13}CO spectra. The correlation between the bands of the different species is shown in Figure 3 (the band positions agree well with those published recently²²

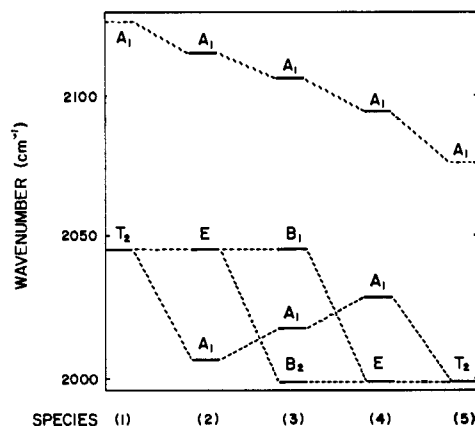

Figure 3. Correlation diagram for C–O stretching vibrations in $\text{Ni}(\text{C}^{16}\text{O})_n(\text{C}^{18}\text{O})_{4-n}$ species. Band positions are given in Table II. Species: (1) $\text{Ni}(\text{C}^{16}\text{O})_4$; (2) $\text{Ni}(\text{C}^{18}\text{O})_3(\text{C}^{16}\text{O})$; (3) $\text{Ni}(\text{C}^{16}\text{O})_2(\text{C}^{18}\text{O})_2$; (4) $\text{Ni}(\text{C}^{16}\text{O})(\text{C}^{18}\text{O})_3$; (5) $\text{Ni}(\text{C}^{18}\text{O})_4$.

in a study of the vibrational spectra of ^{13}C - and ^{18}O -substituted $\text{Ni}(\text{CO})_4$.

Rate data were collected for the formation and subsequent reaction of $\text{Ni}(\text{C}^{16}\text{O})_3(\text{C}^{18}\text{O})$ (*i.e.*, 2007 cm^{-1} in hexane and 2018 cm^{-1} in the gas phase). The kinetically simpler study, the decay of $\text{Ni}(\text{C}^{16}\text{O})_4$, is not feasible owing to the superimposition of bands. In the gas phase, the rate of reaction was independent of C^{18}O concentration over a 100-fold change in the latter. In hexane solution, the rate was independent of C^{18}O concentration over a fivefold change (the smaller range being dictated by solubility considerations). We therefore define the rate constant to correspond with that for substitution by other ligands; *i.e.*, in the reaction step 5, k_{exch} refers to the possible exchange of any of the four C^{16}O groups.



$$\text{rate} = -d[\text{Ni}(\text{C}^{16}\text{O})_4]/dt = k_{\text{exch}}[\text{Ni}(\text{C}^{16}\text{O})_4] \quad (6)$$

The rate constants were calculated by the methods described in the Appendix. The results are given in Table I; at least three determinations were made at each temperature, and the dependence on CO concentration was tested at 20° .

Competition Experiments. In competition experiments in which C^{18}O and Ph_3P were allowed to react simultaneously with $\text{Ni}(\text{C}^{16}\text{O})_4$, both $\text{Ni}(\text{C}^{16}\text{O})_3(\text{C}^{18}\text{O})$ and $\text{Ni}(\text{C}^{16}\text{O})_3(\text{Ph}_3\text{P})$ formed more slowly than in the single-ligand experiments at the same temperature. However, the sum of their rates of formation, which was equal to the rate of reaction of $\text{Ni}(\text{C}^{16}\text{O})_4$, was approximately equal to the rate of either of the single-ligand reactions. With equimolar quantities of C^{18}O and Ph_3P , the latter react about five times as fast. A tenfold excess of Ph_3P over C^{18}O virtually eliminated the exchange reaction. These results are summarized in Table III.

$\text{Ni}(\text{CO})_4$ Scrambling Reaction. The possibility of the scrambling of $\text{Ni}(\text{C}^{16}\text{O})_n(\text{C}^{18}\text{O})_{4-n}$ species (*i.e.*, reaction between these species to exchange CO groups, but without the intervention of free CO) must be considered in the derivation of the kinetic equations which govern

(20) G. Bor, *J. Organometal. Chem.*, **10**, 343 (1967).

(21) H. Haas and R. K. Sheline, *J. Chem. Phys.*, **47**, 2996 (1967).

(22) L. H. Jones, R. S. McDowell, and M. Goldblatt, *ibid.*, **48**, 2663 (1968).

Table III. Competition between C¹⁸O and PPh₃ for Ni(C¹⁶O)₄. Rate Constants^a for Reaction^b at 10°

[PPh ₃], M	Ni(C ¹⁶ O) ₄	10 ⁴ k, sec ⁻¹ Ni(C ¹⁶ O) ₃ (C ¹⁸ O)	Ni(C ¹⁶ O) ₃ (PPh ₃)
0	12.5	12.5	0
0.005	~12.5	~2	~10.5
0.005	~12.5	~0	~12.5

^a For loss of Ni(C¹⁶O)₄ and formation of Ni(C¹⁶O)₃(C¹⁸O) and/or Ni(C¹⁸O)₃(PPh₃). ^b Initial concentrations: Ni(C¹⁶O)₄ = 0.002 M, C¹⁸O ~ 0.005 M, PPh₃ variable.

CO exchange. To test this possibility, Ni(C¹⁶O)₄ and Ni(C¹⁸O)₄ (90% ¹⁸O) were mixed together, in the gas phase and in solution, both with and without free C¹⁶O, and the infrared spectrum was studied at intervals.

In the gas phase, Ni(C¹⁶O)₄ and Ni(C¹⁸O)₄ scrambled within 1 min at 25° to give an equilibrium mixture of the five possible species Ni(C¹⁶O)_n(C¹⁸O)_{4-n}. In experiments where no free C¹⁶O was present no further change occurred.

In experiments where a large excess of free C¹⁶O was present, the initial scrambling occurred to give the same distribution of species as in the previous experiments, and then CO exchange proceeded at a much slower rate, with the formation eventually of Ni(C¹⁶O)₄.

In hexane solution, Ni(C¹⁶O)₄ and Ni(C¹⁸O)₄ scrambled very much more slowly than in the gas phase. In cases where no C¹⁶O was present, equilibrium was not reached in 24 hr at 25°. When C¹⁶O was present, CO exchange was effectively complete in less than 30 min.

We conclude that two different types of reaction can occur, *i.e.*

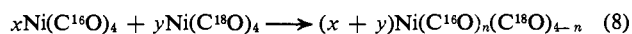

Reaction 7, which is the one usually referred to as the CO exchange reaction, occurs at approximately the same rate both in the gas phase and in solution. Reaction 8, which we will refer to as the Ni(CO)₄ scrambling reaction, occurs in the gas phase at a very much greater rate (>100) than CO exchange; however, in hexane solution the scrambling is very much slower than CO exchange (<0.01).

Discussion

Based on the observed first-order rate law and the other results of the preceding section, we consider that the most plausible mechanism for reaction 1 consists of a rate-determining first-order step (9), followed by rapid reaction of the active intermediate (10), *i.e.*, the S_N1 mechanism.

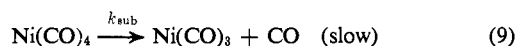

In particular, the similarity of the rates and activation parameters (Table I) for CO exchange and Ph₃P substitution, in *n*-hexane, and the observation of direct competition between these nucleophiles (Table III) confirms the postulate of a common active intermediate. Furthermore, the values of the activation parameters suggest a dissociative activation step. The mean Ni-C bond dissociation energy is 35 kcal mol⁻¹ (by

calorimetry²³); thus the enthalpy of activation, 25 kcal/mol⁻¹, is consistent with rupture of a Ni-C bond. The positive entropy of activation is also consistent with this process.

The similarity of the activation parameters for CO exchange in the gas phase and in solution suggests a similarity of mechanism in the two phases. However, this creates a conflict with the conclusions from previous kinetic measurements²⁴ of Ni(CO)₄ decomposition in the gas phase. The decomposition is a much slower process (*ca.* 10⁻²) than CO exchange at 30°. The measurements were interpreted to show that the rate was determined by a single dissociation step, postulated as (9), with activation parameters Δ*H** ≈ 19 kcal mol⁻¹ and Δ*S** ≈ -16 eu. We have reinvestigated the gas-phase thermal decomposition to resolve this conflict, and the results are reported fully in the following paper.⁹ Briefly, we find that the kinetics are best represented by a mechanism involving two successive activation steps, with the following activation parameters for the total process: Δ*H** ≈ 45 kcal mol⁻¹, Δ*S** ≈ +43 eu. This is consistent with two successive dissociation steps, the first corresponding to the reaction (9) postulated for CO exchange.

The somewhat different rates and activation parameters (Table I) for Ph₃P substitution in toluene, relative to hexane, substantiates some earlier findings by Angelici and Leech;⁷ *i.e.*, *k*_{sub} (sec⁻¹) at 25° is equal to from 6.87 × 10⁻³ in cyclohexane to 19.4 × 10⁻³ in toluene, with Δ*H** from a study over a 9° temperature range equal to 20.4 and 26.6 kcal mol⁻¹, respectively. It is possible that increased solvation of the active intermediate, as postulated by Angelici and Leech,⁷ causes this effect. In our experiments we observed a small increase in substitution rate in the more concentrated solutions of Ph₃P (see Results); we consider that this effect may also be ascribed to a change in solvent properties.

The occurrence of the Ni(CO)₄ scrambling reaction in the gas phase would seem to suggest the possible formation and decomposition of a binuclear species, with bridging CO groups.

Results from Previous CO Exchange. The rate constants at different temperatures obtained by the original ¹⁴CO exchange experiments³⁻⁵ gave a reasonably linear Arrhenius plot, but with a much lower activation energy than that obtained by our present method. If we assume that the present results are corrected, then it is clear that the original experiments introduced a systematic error. Furthermore, the two methods give approximately the same values for the rate constant 25° (room temperature); the error in the earlier method apparently increases in proportion to the lowering in temperature.

In the earlier experiments, a mixture of ¹²CO and ¹⁴CO was pumped through a solution of Ni(¹²CO)₄. The reaction was assumed to occur in, and at the temperature of, the solution. The radioactivity of a substantial gas phase (at room temperature) was measured. It is now clear that some exchange always occurred in the gas phase, because of the volatility of Ni(CO)₄. We have shown that the rate of exchange in the gas

(23) F. A. Cotton, A. K. Fischer, and G. Wilkinson, *J. Am. Chem. Soc.*, **81**, 800 (1959).

(24) R. K. Chan and R. McIntosh, *Can. J. Chem.*, **40**, 845 (1962).

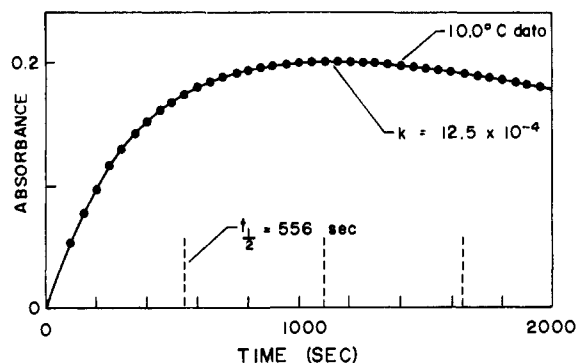

Figure 4. Demonstration of curve fitting. Calculated curve (solid line) for the trial value of k_{exch} which gave the best fit to the experimental data (points), comprising $\text{Ni}(\text{C}^{16}\text{O})_3(\text{C}^{18}\text{O})$ absorbance against time during the reaction of $\text{Ni}(\text{C}^{16}\text{O})_4$ with C^{18}O in *n*-hexane at 10° .

phase is approximately twice that in solution at the same temperature. Approximate calculations, using measured values of the vapor pressure of $\text{Ni}(\text{CO})_4$ over solutions, and taking into account the higher temperature of the gas phase, show that up to 50% of the exchange could have occurred in the gas phase in the most unfavorable case. This effect would be greatest at the lowest solution temperature and would result in an "observed" activation energy lower than the "true" activation energy by approximately the required amount.

This deduction has been shown²⁵ to be qualitatively correct; in a ^{14}CO exchange experiment at 0° , in which the gas phase was cooled considerably below room temperature, the "observed" rate constant was lower than the value obtained when the gas phase was not cooled. It seems probable that this error will be present to some extent in all ^{14}CO exchange experiments (using this method) conducted with volatile carbonyls.

Acknowledgment. We wish to thank Dr. P. M. Henry for helpful discussions. We gratefully acknowledge the use of NUC-0062 from the Northwestern University Computing Center Library and the financial support of the National Science Foundation.

Appendix. CO Exchange Calculations

Introduction. The problem is to calculate k_{exch} , as defined by (5) and (6), from experimental data consisting of measurements of the absorbance of $\text{Ni}(\text{C}^{16}\text{O})_3(\text{C}^{18}\text{O})$ against time, for the reaction of $\text{Ni}(\text{C}^{16}\text{O})_4$ with C^{18}O . In our analysis, we have ignored any isotope effect on the rate of reaction, considering this to be negligible compared to the other experimental errors.

We concluded earlier that, in solution, the rate of the $\text{Ni}(\text{CO})_4$ scrambling reaction (8) is negligible compared to the rate of CO exchange (7). The rate equations for the reaction in solution can therefore be derived from the stepwise reaction sequence

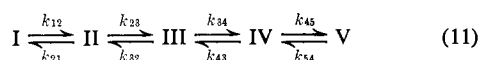

where the species $\text{Ni}(\text{C}^{16}\text{O})_4$, $\text{Ni}(\text{C}^{16}\text{O})_3(\text{C}^{18}\text{O})$, etc. are represented by I, II, etc. Reaction from left to

(25) P. M. Henry and L. R. Kangas, private communication.

right requires the presence of free C^{18}O , and from right to left requires free C^{16}O .

In the gas phase, the rate of $\text{Ni}(\text{CO})_4$ scrambling is much greater than the exchange. Reaction sequence 11 no longer applies. Instead, the concentrations of species I–V at any instant are determined statistically, from the ratio of coordinated C^{16}O to coordinated C^{18}O . This can be related to k_{exch} by consideration of the gross exchange process.

Gross Exchange. We shall consider a closed system containing a moles of $\text{Ni}(\text{CO})_4$ and b moles of free CO. The gross rate of exchange is defined as the rate of exchange of all CO groups, whether of like or different isotopes. Assuming no isotope effect, the gross rate of exchange is constant. However, the rate at which "bound" C^{16}O can be replaced by "free" C^{18}O is proportional to (i) the fraction of bound CO that is C^{16}O , and (ii) the fraction of free CO that is C^{18}O , and *vice versa*.

Assuming as the initial condition that all the $\text{Ni}(\text{CO})_4$ is in the C^{16}O form, and that the free CO contains a fraction x of C^{18}O , then it can be shown²⁶ that

$$F = \frac{bx}{4a + b} \{1 - \exp[-k_{\text{exch}}t(4a + b)/4b]\} \quad (12)$$

where F is the fraction of bound CO which has become C^{18}O after time t .

This result is based on statistical considerations only and is independent of the mechanism of exchange. It can therefore be applied both to reactions in solution and in the gas phase.

Reaction in Solution. Consider the reaction system 11. Forward reaction (left to right) consists of bound C^{16}O being replaced by free C^{18}O and *vice versa*. Thus, the reactions are subject to the statistical restrictions previously considered, and these appear in the following set of five simultaneous rate equations

$$\left. \begin{aligned} \dot{c}_1 &= -k_{12}c_1g + k_{21}c_2(1 - g) \\ \dot{c}_2 &= +k_{12}c_1g - k_{21}c_2(1 - g) - \\ &\quad k_{23}c_2g + k_{32}c_3(1 - g) \\ &\text{and similarly } \dot{c}_3, \dot{c}_4, \dot{c}_5 \end{aligned} \right\} \quad (13)$$

The concentrations of species I, II, etc., are represented by c_1, c_2 , etc. The rate constants are related to k_{exch} by (14), in which f_{nm} is the fraction of the CO groups in the species N which can be replaced in the reaction $\text{N} \rightarrow \text{M}$ (e.g., $f_{23} = f_{43} = 3/4$).

$$k_{\text{nm}} = f_{\text{nm}}k_{\text{exch}} \quad (14)$$

The factor g is equal to the fraction of the free CO which is C^{18}O at a given time. Therefore, from (12)

$$g = x - \frac{4ax}{4a + b} \{1 - \exp[-k_{\text{exch}}t(4a + b)/4b]\} \quad (15)$$

The rate constant, k_{exch} , was obtained from the data (c_2 against t) by a curve-fitting technique. Using the known starting conditions (a, b, x) and a trial value for k_{exch} , the set of equations (13) was solved for the concentrations, c_n , using a numerical integration method (Runge-Kutta²⁷). The trial value of k_{exch} was varied

(26) A. A. Frost and R. G. Pearson, "Kinetics and Mechanism of Inorganic Reactions," 2nd ed, John Wiley and Sons, Inc., New York, N. Y., 1961, p 192.

to produce optimum agreement between the calculated and observed c_2 , and hence the "best" value of k_{exch} . An example of this is given in Figure 4.

Reaction in the Gas Phase. The concentrations of species I–V are here determined by the degree of gross exchange only. If F is the fraction of *bound* CO which is C^{18}O at any time, related to k_{exch} by (12), and W_r is the mole fraction of the $\text{Ni}(\text{CO})_4$ species containing r C^{18}O groups, then

$$W_r = \frac{4!}{(4-r)!r!} F^r (1-F)^{4-r} \quad (16)$$

This relationship is demonstrated in Figure 5.

The rate constants were obtained as follows. The mole fraction (W_1) of $\text{Ni}(\text{C}^{16}\text{O})_3(\text{C}^{18}\text{O})$ was calculated for 10,000 values of F , from 0 to 1. W_1 reaches a maximum value ($=0.4219$) when $F = 1/4$, and the maximum in the experimental absorbance–time curve (Figure 4) for a gas-phase reaction corresponds to this value. Using this relationship, for a given set of experimental data each absorbance reading was converted to mole fraction units. The value of F for each point was then obtained by interpolation from the calculated F/W_1 tabulation.

Rewriting equation 12 as follows

$$F = A \{1 - \exp(-Bk_{\text{exch}}t)\} \quad (17)$$

(27) G. N. Lance, "Numerical Methods for High Speed Computers," Iliffe Ltd., London, 1960, Chapter 3.

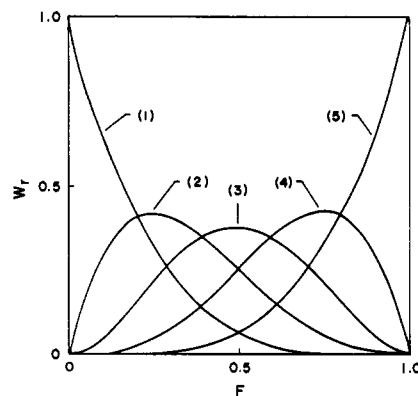

Figure 5. Relative concentrations of $\text{Ni}(\text{C}^{16}\text{O})_n(\text{C}^{18}\text{O})_{4-n}$ species under equilibrium conditions, calculated from eq 16. (1) $\text{Ni}(\text{C}^{16}\text{O})_4$, (2) $\text{Ni}(\text{C}^{16}\text{O})_3(\text{C}^{18}\text{O})$, (3) $\text{Ni}(\text{C}^{16}\text{O})_2(\text{C}^{18}\text{O})_2$, (4) $\text{Ni}(\text{C}^{16}\text{O})(\text{C}^{18}\text{O})_3$, (5) $\text{Ni}(\text{C}^{18}\text{O})_4$. W_r = mole fraction of the $\text{Ni}(\text{CO})_4$ species containing r C^{18}O groups. F = mole fraction of C^{18}O in coordinated CO.

where A and B are known constants related to the starting conditions, then

$$\ln [1 - (F/A)] = -Bk_{\text{exch}}t \quad (18)$$

The value of k_{exch} for each data set was determined from the slope of the linear plot of $\ln [1 - (F/A)]$ against t .

The Kinetics and Mechanism of the Thermal Decomposition of Nickel Tetracarbonyl

J. Philip Day, Ralph G. Pearson, and Fred Basolo

Contribution from the Department of Chemistry, Northwestern University, Evanston, Illinois 60201. Received July 11, 1968

Abstract: The rate of decomposition of $\text{Ni}(\text{CO})_4$ in the gas phase has been measured, between 47.3 and 66.0°, by infrared spectrophotometry. The final stage of the decomposition occurs heterogeneously, but the preceding steps may occur heterogeneously (<10%) or homogeneously (>90% of the total reaction under the conditions used). The homogeneous process obeys rate law 3, in which $k_{21}/k_{23} > 10^5$ l. mol⁻¹ and $k_{12}k_{23}/k_{21}$ ($=k_c$, the composite rate constant) ranged from 5.67×10^{-9} to 2.80×10^{-7} mol l.⁻¹ sec⁻¹ with activation parameters $\Delta H_c^* = 44.7 \pm 3$ kcal mol⁻¹ and $\Delta S_c^* = 43 \pm 8$ eu. The most plausible mechanism is (4), and it is shown that the results are consistent with the activation parameters for CO *exchange* for which the mechanism of step 1 in (4) has been postulated. Previous studies of the thermal decomposition gave much smaller activation energies and the reasons for this discrepancy are discussed.

The rate of the decomposition of nickel carbonyl (1) in the gas phase has been extensively studied,¹⁻⁵ but some doubt still exists as to the mechanism and activation parameters of the reaction.



- (1) A. Mittasch, *Z. Physik. Chem.*, **40**, 1 (1902).
 (2) A. P. Garratt and H. W. Thompson, *J. Chem. Soc.*, 524, 1817, 1822 (1934).
 (3) C. E. H. Bawn, *Trans. Faraday Soc.*, **31**, 440 (1935).
 (4) R. K. Chan and R. McIntosh, *Can. J. Chem.*, **40**, 845 (1962).
 (5) A. B. Callear, *Proc. Roy. Soc. (London)*, **A265**, 71 (1961).

The object of this paper is to report some new measurements of the rate of thermal decomposition and to discuss the mechanism in the light of our recent investigation⁶ of the mechanism of CO exchange with $\text{Ni}(\text{CO})_4$.

Garratt and Thompson, from a study of the photochemical and thermal decompositions,² postulated a mechanism (2) in which $\text{Ni}(\text{CO})_3$ appeared as an intermediate. Assuming a steady-state concentration of

- (6) J. P. Day, F. Basolo, and R. G. Pearson, *J. Am. Chem. Soc.*, **90**, 6927 (1968).